

THE NEW STANDARD

in profile processing

THE PBZ PROFILE PROCESSING CENTRE

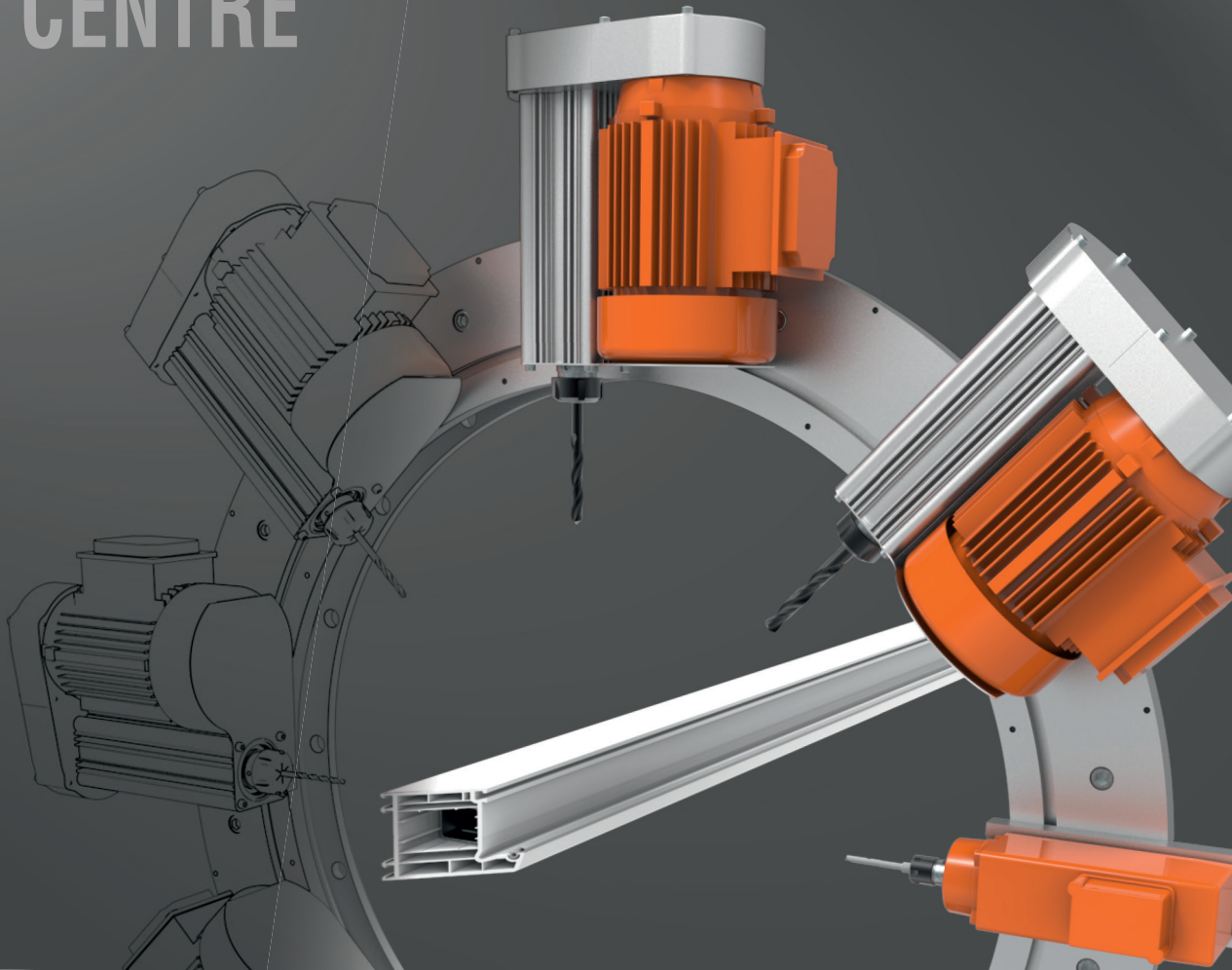

PBZ THE ALL-ROUND PROFILE GENIUS

You fabricate windows and doors. We produce the machines that make your workshop efficient.

Our PBZ profile processing centre optimises your work on the profiles. All stages of profile processing –milling, drilling and fastening of reinforcement –are executed in a single pass. The core of the system is the infinitely rotatable tool collar. The collar's position is easily programmable, so that the profile precisely undergoes all processing and can be removed fully complete from the downstream buffering conveyor.

Thanks to our extensive experience and progressive approach, we are continually developing new time-saving and cost-reducing tactics, so you can be assured that you are processing window and door profiles with latest available technology.



PROVEN

COMPACT

SOPHISTICATED DESIGN

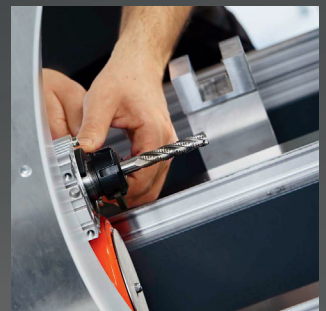

The PBZ is designed on a simple and reliable modular basis. Reduced floor space, user-friendly maintenance, easy access from all sides are just some of the highlights. The operator simply identifies the profile section via the interface screen and confirms with the bar code scanner. The operator is graphically supported on the full HD touchscreen by simple menus in the language of your choice.

Our PBZ is the correct investment to improve your competitiveness!

- smaller footprint
- clear layout of all components
- full access allows rapid tool replacement and simple servicing and maintenance
- suitable for processing all common profile sections and lengths
- if requested, our application technicians can program new profiles or profile systems and install them directly into the machine control system by remote servicing
- the integrated remote servicing software means that we are always there to help our customers when needed.

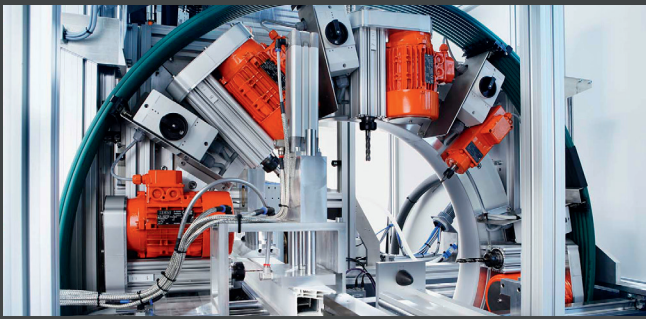

SUSTAINABLE

EFFICIENT



CONTROL
SYSTEM



THE
RESULT

- simple menu operation
- plain text operation in your language
- precise execution of the processing through scanner-controlled profile detection
- processing and drilling patterns are stored in the machine control system
- 3D simulation of processing and drilling patterns
- Fault diagnosis with 3D graphic simulation
- permanently stored service intervals

- fast and precise processing of your window and door profiles
- high performance with high flexibility in a small space
- proven simple operation
- optimal material consumption through fault-free production
- an investment that will pay dividends for your business
- access to our extensive global experience

We understand your business ...

The market expects speed, precision and efficiency. We can help with our PBZ profile processing centre.

- an investment that will pay dividends for your business
- low-maintenance and fast retooling
- individually programmable for your end products
- User-friendly through simple menus

Should you have any questions about the design, function or operation of the new PBZ we will be happy to help you. Just give us a call!

Thorwesten Maschinenbau GmbH

Daimlerring 45

D-59269 Beckum

Tel. +49 2521 8202-0

Fax +49 2521 8202-22

Email info@thorwesten.net

